

## SOT-23 Plastic-Encapsulate MOSFETS

### Features

- TrenchFET
- PowerMOSFET ESD Protected: 3000 V
- N-Channel 20-V (D-S) MOSFET

### MECHANICAL DATA

- Case style:SOT-23molded plastic
- Mounting position:any

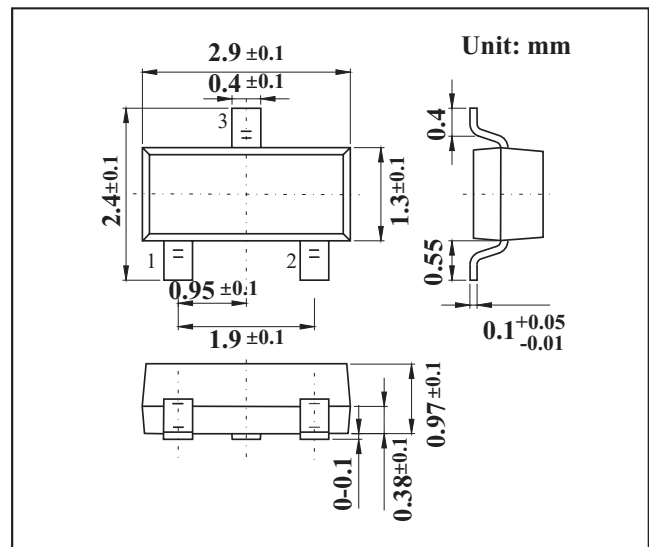

### MAXIMUM RATINGS AND CHARACTERISTICS

@ 25°C Ambient Temperature (unless otherwise noted)

Parameter	Symbol	5secs	Steady State	Unit
Drain-Source Voltage	VDS	20		V
Gate-Source Voltage	VGS	±12		
Continuous Drain Current (TJ =150°C) *1	ID	4.9	3.77	A
		3.9	3	
Pulsed Drain Current	IDM	15		
Avalanche Current*2	IAS	15		
Single Avalanche Energy	EAS	11.25		
Continuous Source Current (Diode Conduction)*1	IS	1		
Power Dissipation *1	PD	1.25	0.75	W
		0.8	0.48	
Operating Junction and Storage Temperature Range	TJ, T stg	-55 to 150		°C

\*1 Surface Mounted on 1"X 1" FR4 Board.

\*2 Pulse width limited by maximum junction temperature. Thermal Resistance Ratings

Parameter	t ≤ 5 sec	Symbol	Typical	Maximum	Unit
Maximum Junction-to-Ambient *	Steady-State	RthJA	75	100	°C/W
	Steady-State		120	166	
Maximum Junction-to-Foot (Drain)	Steady-State	RthJF	40	50	

\* Surface Mounted on 1"X 1" FR4 Board.

### MOSFET ELECTRICAL CHARACTERISTICS Ta=25 °C unless otherwise specified

Parameter	Symbol	Testconditions	Min	Typ	Max	Unit
Drain-Source Breakdown Voltage	V(BR)DSS	VGS = 0 V, ID = 250 μA	20			V
Gate Threshold Voltage	VGS(th)	VDS = VGS, ID = 250 μA	0.45			V
Gate-Body Leakage	IGSS	VDS = 0 V, VGS = ±4.5 V			±1.5	μA
Zero Gate Voltage Drain Current	IDSS	VDS = 16V, VGS = 0 V			1	μA
		VDS = 16V, VGS = 0 V, TJ = 70 °C			75	
On-State Drain Current*	ID(on)	VDS ≥ 10 V, VGS = 4.5 V	15			A
Drain Source On State Resistance*	RDS(on)	VGS = 4.5 V, ID = 5.0A		0.027	0.033	Ω
		VGS = 2.5 V, ID = 4.5A		0.033	0.040	
		VGS = 1.8 V, ID = 4.0A		0.042	0.051	
Forward Transconductance	gfs	VDS = 15V, ID = 5.0 A		4.0		S
Schottky Diode Forward Voltage*	VSD	IS = 1.0 A, VGS = 0 V		0.8	1.2	V
Total Gate Charge	Qg	VDS = 10 V, VGS = 4.5 V, ID = 5.0 A		11.0	14.0	nC
Gate-Source Charge	Qgs			1.5		
Gate-Drain Charge	Qgd			2.1		
Turn-On Delay Time	td(on)	VDD=10V, RL=10 Ω ID=1.0A, VGEN=4.5V, RG=6 Ω *		0.53	0.8	ns
Rise Time	tr			1.4	2.2	
Turn-Off Delay Time	td(off)			13.5	20	
Fall Time	tf			5.9	9	
Source-Drain Reverse Recovery Time	trr	IF = 1.0 A, di/dt = 100 A/ μs		13	25	ns

\* Pulse test :Pulse width ≤300 μs, duty cycle ≤2%

## RATINGS AND CHARACTERISTIC CURVES

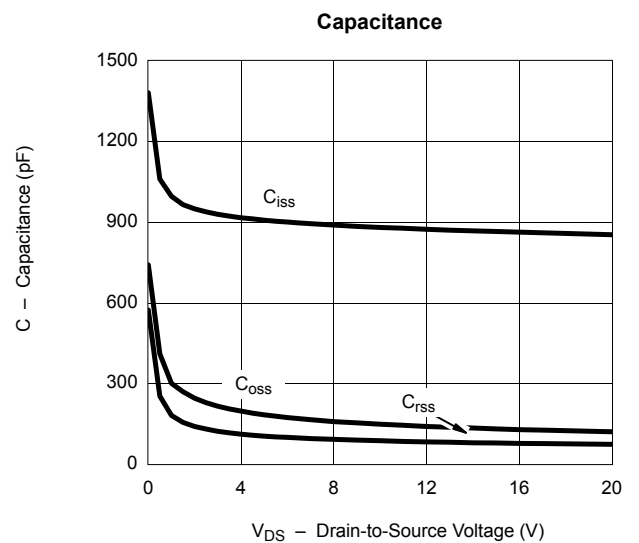
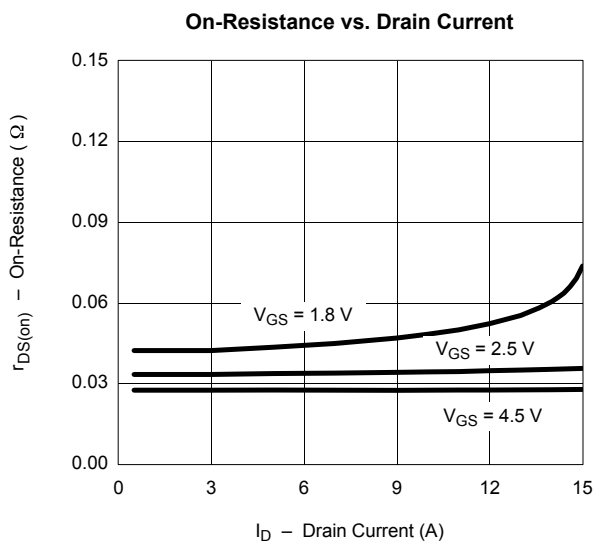
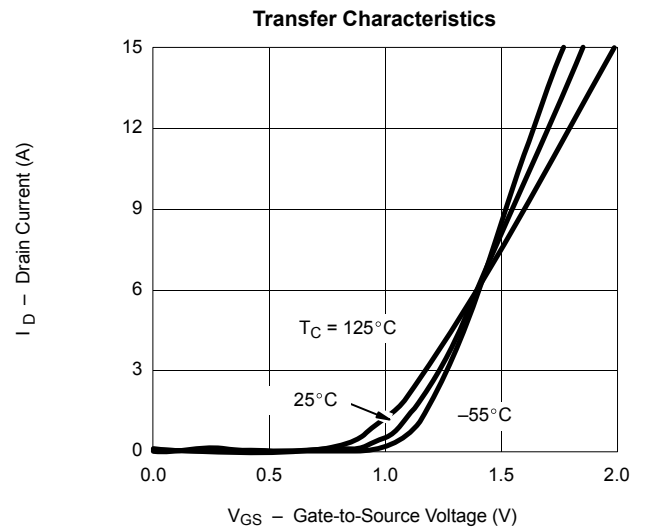
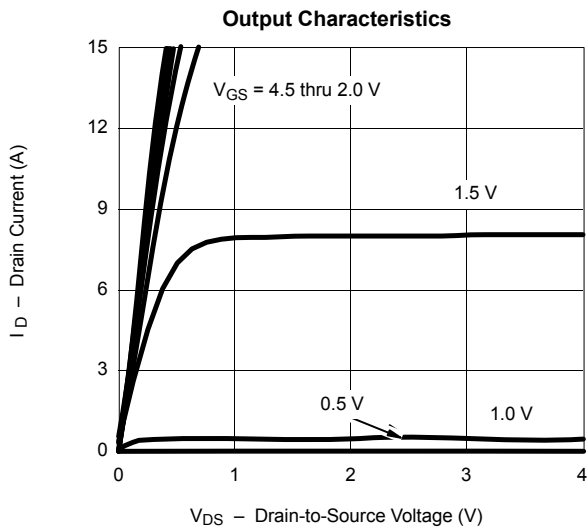
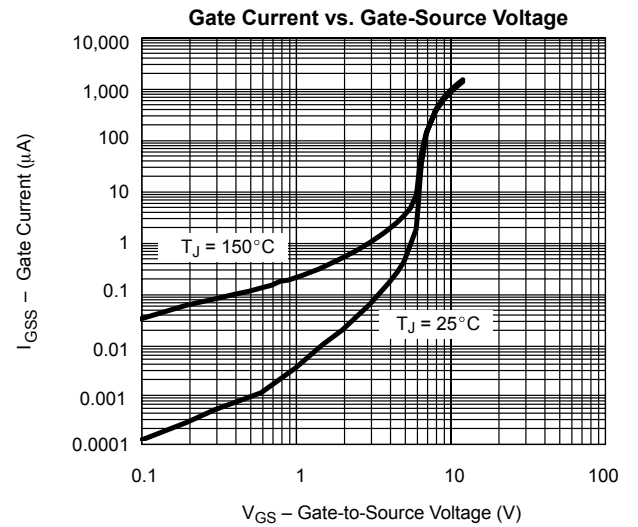
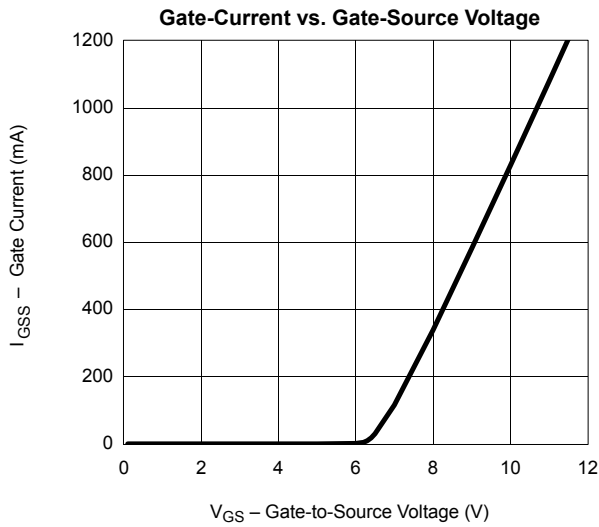

## RATINGS AND CHARACTERISTIC CURVES

Gate Charge

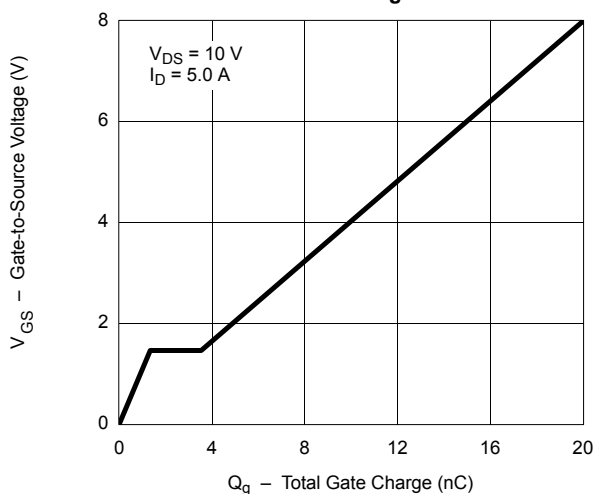

On-Resistance vs. Junction Temperature

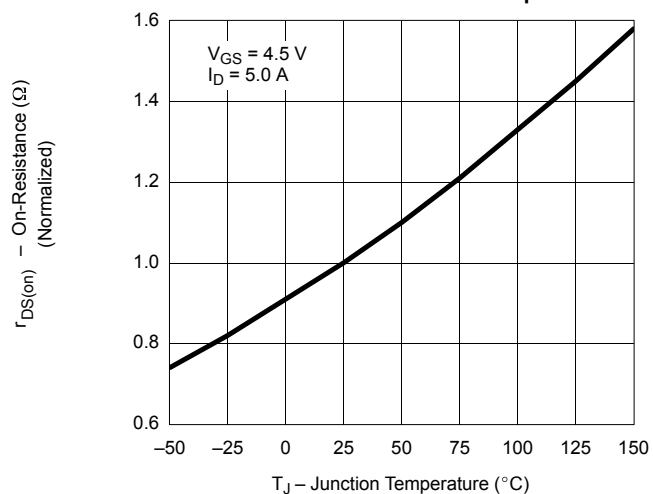

Source-Drain Diode Forward Voltage

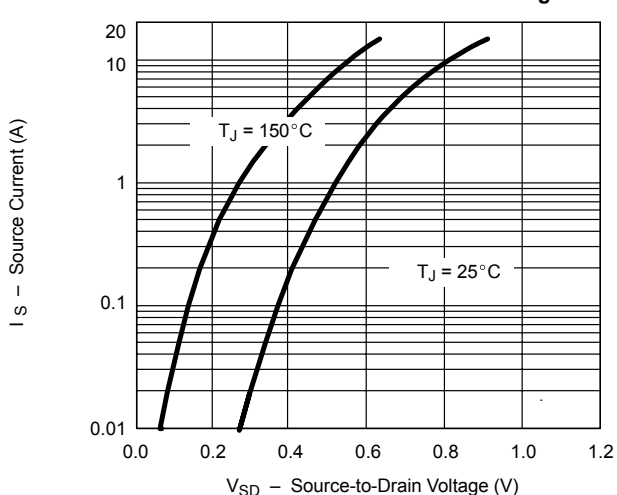

On-Resistance vs. Gate-to-Source Voltage

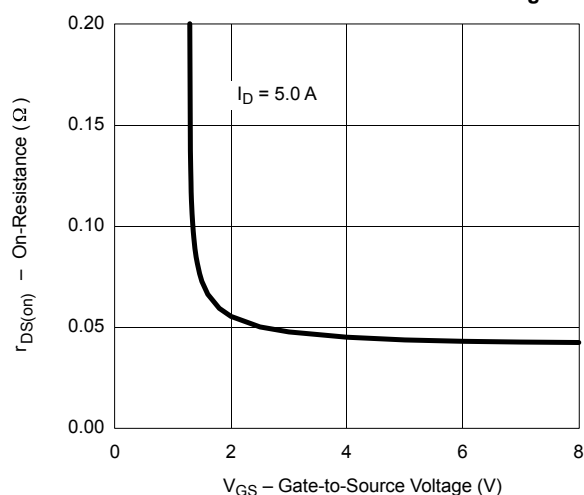

Threshold Voltage

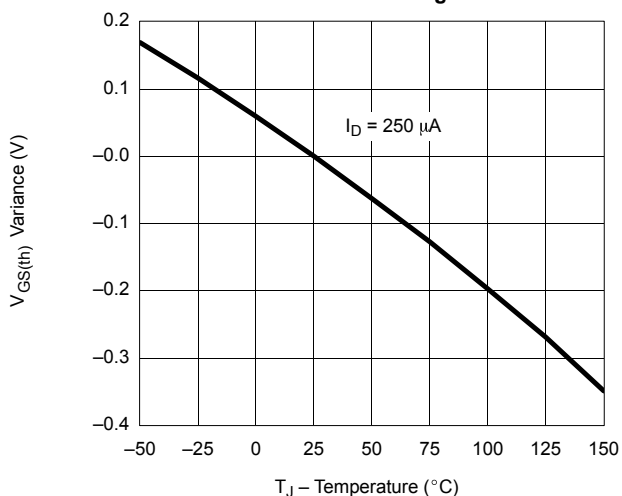

Single Pulse Power

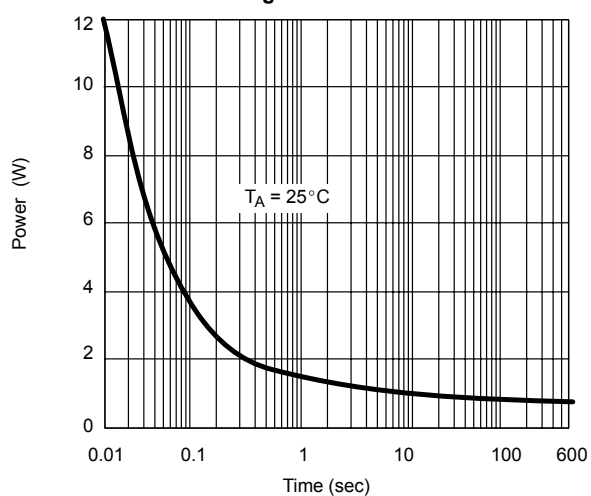

## RATINGS AND CHARACTERISTIC CURVES

