

SOT-23 Plastic-Encapsulate MOSFETS

Features

- N-Channel Enhancement MOSFET
- Low On-Resistance: RDS(ON) Low Gate Threshold Voltage
- Low Input Capacitance Fast Switching Speed
- Low Input/Output Leakage
- ESD Protected 2KV HBM

MECHANICAL DATA

- Case style:SOT-23molded plastic
- Mounting position:any

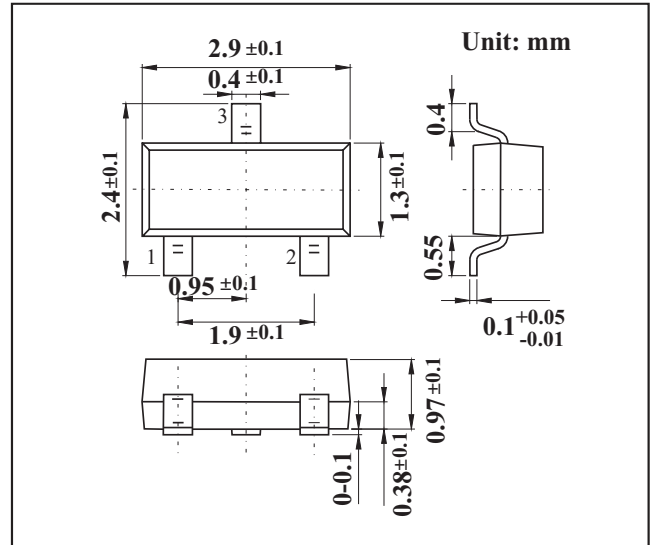

MAXIMUM RATINGS AND CHARACTERISTICS

@ 25°C Ambient Temperature (unless otherwise noted)

Parameter	Symbol	Rating	Unit
Drain-Source Voltage	V _{DS}	60	V
Gate-Source Voltage (Continuous)	V _{GS}	±20	
Drain Current -Continuous (Note:1)	I _D	300	mA
-Pulsed		800	
Power Dissipation (Note 1)	P _D	350	mW
Thermal Resistance Junction-to-Ambient	R _{thJA}	357	°C/W
Junction Temperature	T _J	150	°C
Junction and Storage Temperature Range	T _{stg}	- 55 to 150	

Notes: 1. Device mounted on FR-4 PCB.

Mosfet Electrical Characteristics T_A=25°C unless otherwise specified)

Parameter	Symbol	Test Conditions	Min	Typ	Max	Unit
Drain-Source Breakdown Voltage (Note.2)	V _{DSS}	I _D =100 μA, V _{GS} =0V	60			V
Zero Gate Voltage Drain Current (Note.2)	I _{DSS}	V _{DS} =60V, V _{GS} =0V			1	μA
Gate-Body Leakage Current (Note.2)	I _{GSS}	V _{DS} =0V, V _{GS} =±20V			±10	uA
Gate Threshold Voltage (Note.2)	V _{GS(th)}	V _{DS} = 10V, I _D = 1mA	1	1.6	2.5	V
Static Drain-Source On-Resistance (Note.2)	R _{DS(on)}	V _{GS} =10V, I _D =500mA			2	Ω
		V _{GS} =10V, I _D =50mA			3	
Forward Transfer Admittance (Note.2)	Y _{fs}	V _{GS} =10V, I _D =200mA	80			ms
Input Capacitance	C _{iss}	V _{GS} =0V, V _{DS} =25V, f=1MHz			50	pF
Output Capacitance	C _{oss}				25	
Reverse Transfer Capacitance	C _{rss}				5	
Total Gate Charge	Q _g	V _{GS} =4.5V, V _{DS} =15V, I _D =200mA			0.8	nC
Turn-On DelayTime	t _{d(on)}	I _D =200mA, V _{DS} =30V, R _G =10Ω, V _{GEN} =10V, R _L =150Ω			20	ns
Turn-Off DelayTime	t _{d(off)}				40	

Note: 2. Short duration test pulse used to minimize self-heating effect.

RATINGS AND CHARACTERISTIC CURVES

Typical Characteristics

