

**SOT-23 Plastic-Encapsulate MOSFETS**
**FEATURE**

- High dense cell design for extremely low RDS(ON).
- Exceptional on-resistance and maximum DC current capability
- P-Channel Enhancement Mode Field Effect Transistor

**MECHANICAL DATA**

- Case style:SOT-23molded plastic
- Mounting position:any

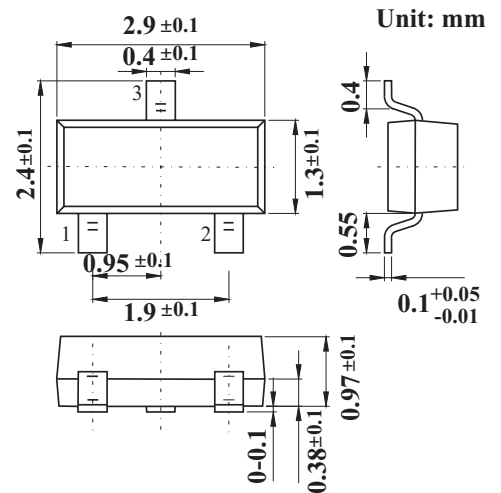

$V_{(BR)DSS}$	<b>RDSS(on) MAX</b>	$I_D$
-30 V	65mΩ@-10V	-4.2A
	75mΩ@-4.5V	
	90mΩ@-2.5V	

**MAXIMUM RATINGS AND CHARACTERISTICS**

@ 25°C Ambient Temperature (unless otherwise noted)

Parameter	Symbol	Value	Unit
Drain-Source Voltage	$V_{DS}$	-30	V
Gate-Source Voltage	$V_{GS}$	±12	V
Continuous Drain Current	$I_D$	-4.2	A
Power Dissipation	$P_D$	350	mW
Thermal Resistance from Junction to Ambient (t<5s)	$R_{\theta JA}$	357	°C/W
Junction Temperature	$T_J$	150	°C
Storage Temperature	$T_{STG}$	-55~+150	°C

**MOSFET ELECTRICAL CHARACTERISTICS** Ta=25 °C unless otherwise specified

Parameter	Symbol	Test Condition	Min	Typ	Max	Unit
<b>Off characteristics</b>						
Drain-source breakdown voltage	$V_{(BR)DSS}$	$V_{GS} = 0V, I_D = -250\mu A$	-30			V
Zero gate voltage drain current	$I_{DSS}$	$V_{DS} = -24V, V_{GS} = 0V$			-1	$\mu A$
Gate-source leakage current	$I_{GSS}$	$V_{GS} = \pm 12V, V_{DS} = 0V$			$\pm 100$	nA
<b>On characteristics</b>						
Drain-source on-resistance (note 1)	$R_{DS(on)}$	$V_{GS} = -10V, I_D = -4.2A$		50	65	m $\Omega$
		$V_{GS} = -4.5V, I_D = -4A$		60	75	m $\Omega$
		$V_{GS} = -2.5V, I_D = -1A$		75	90	m $\Omega$
Forward transconductance (note 1)	$g_{FS}$	$V_{DS} = -5V, I_D = -5A$	7			S
Gate threshold voltage	$V_{GS(th)}$	$V_{DS} = V_{GS}, I_D = -250\mu A$	-0.7	-0.9	-1.3	V
<b>Dynamic characteristics</b> (note 2)						
Input capacitance	$C_{iss}$	$V_{DS} = -15V, V_{GS} = 0V, f = 1MHz$		954		pF
Output capacitance	$C_{oss}$			115		pF
Reverse transfer capacitance	$C_{rss}$			77		pF
<b>Switching characteristics</b> (note 2)						
Turn-on delay time	$t_{d(on)}$	$V_{GS} = -10V, V_{DS} = -15V,$ $R_L = 3.6\Omega, R_{GEN} = 6\Omega$			6.3	ns
Turn-on rise time	$t_r$				3.2	ns
Turn-off delay time	$t_{d(off)}$				38.2	ns
Turn-off fall Time	$t_f$				12	ns
<b>Drain-source diode characteristics and maximum ratings</b>						
Diode forward voltage (note 1)	$V_{SD}$	$I_S = -1A, V_{GS} = 0V$			-1	V

**Note :**

1. Pulse Test : Pulse width  $\leq 300\mu s$ , duty cycle  $\leq 2\%$ .
2. These parameters have no way to verify.

## RATINGS AND CHARACTERISTIC CURVES

