

## SOT-23 Plastic-Encapsulate MOSFETS

### FEATURE

- TrenchFET Power MOSFET
- N-Channel Enhancement Mode Field Effect Transistor

### MECHANICAL DATA

- Case style:SOT-23molded plastic
- Mounting position:any

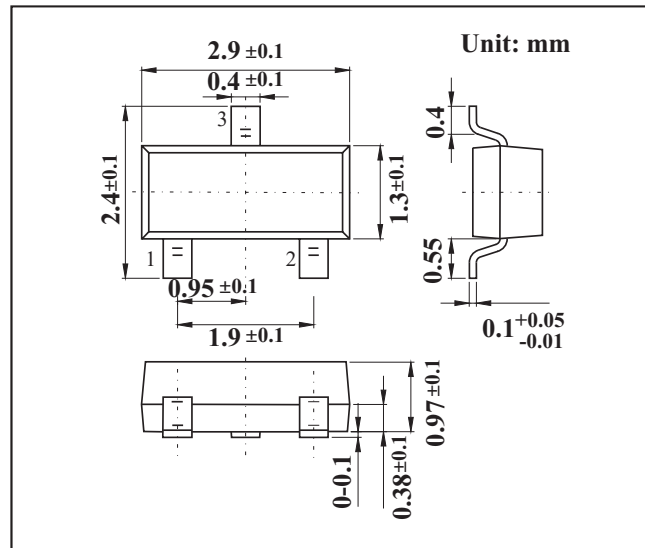

### MAXIMUM RATINGS AND CHARACTERISTICS

@ 25°C Ambient Temperature (unless otherwise noted)

Parameter	Symbol	Value	Unit
Drain-source voltage	$V_{DS}$	30	V
Gate-source voltage	$V_{GS}$	±20	V
Continuous drain current (t ≤10s)	$I_D$	5.8	A
Pulsed drain current *	$I_{DM}$	30	A
Thermal resistance from junction to ambient	$R_{\theta JA}$	357	°C/W
Junction temperature	$T_J$	150	°C
Storage temperature	$T_{stg}$	-55~ 150	°C

\* Repetitive rating : Pulse width limited by maximum junction temperature.

$V_{(BR)DSS}$	$R_{DS(on)MAX}$	$I_D$
30V	30mΩ@ 10V	5.8A
	42mΩ@4.5V	

**MOSFET ELECTRICAL CHARACTERISTICS** Ta=25 °C unless otherwise specified

Parameter	Symbol	Test Condition	Min	Typ	Max	Units
<b>STATIC PARAMETERS</b>						
Drain-source breakdown voltage	$V_{(BR)DSS}$	$V_{GS} = 0V, I_D = 250\mu A$	30			V
Zero gate voltage drain current	$I_{DSS}$	$V_{DS} = 30V, V_{GS} = 0V$			1	$\mu A$
Gate-body leakage current	$I_{GSS}$	$V_{GS} = \pm 20V, V_{DS} = 0V$			$\pm 100$	nA
Gate threshold voltage	$V_{GS(th)}$	$V_{DS} = V_{GS}, I_D = 250\mu A$	1	1.4	3	V
Drain-source on-resistance (note 1)	$R_{DS(on)}$	$V_{GS} = 10V, I_D = 5.8A$		23	30	m $\Omega$
		$V_{GS} = 4.5V, I_D = 4.8A$		31	42	$\Omega$
Forward tranconductance (note 1)	$g_{FS}$	$V_{DS} = 5V, I_D = 5.8A$	5			S
Diode forward voltage	$V_{SD}$	$I_S = 1A$			1	V
<b>DYNAMIC PARAMETERS (note 2)</b>						
Input capacitance	$C_{iss}$	$V_{DS} = 15V, V_{GS} = 0V, f = 1MHz$			820	pF
Output capacitance	$C_{oss}$			118		pF
Reverse transfer capacitance	$C_{rss}$			85		pF
Gate resistance	$R_g$	$V_{DS} = 0V, V_{GS} = 0V, f = 1MHz$			1.5	$\Omega$
<b>SWITCHING PARAMETERS (note 2)</b>						
Turn-on delay time	$t_{d(on)}$	$V_{GS} = 10V, V_{DS} = 15V, R_L = 2.6\Omega, R_{GEN} = 3\Omega$			6.5	ns
Turn-on rise time	$t_r$			3.1		ns
Turn-off delay time	$t_{d(off)}$			15.1		ns
Turn-off fall time	$t_f$			2.7		ns

**Note :**

1. Pulse Test : Pulse width  $\leq 300\mu s$ , duty cycle  $\leq 0.5\%$ .
2. These parameters have no way to verify.

## RATINGS AND CHARACTERISTIC CURVES

Output Characteristics

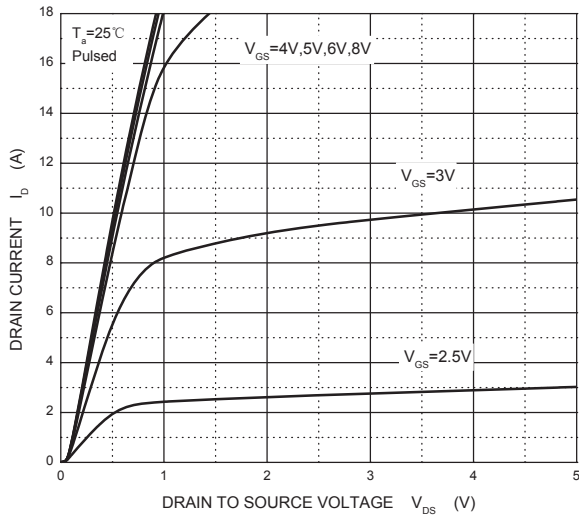

Transfer Characteristics

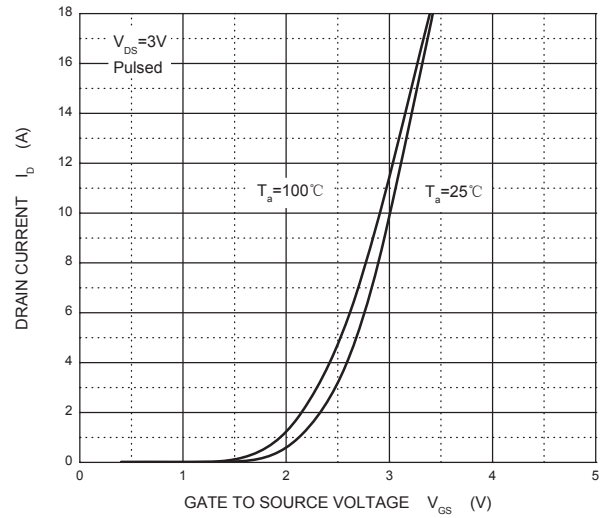

$R_{DS(ON)}$  —  $I_D$

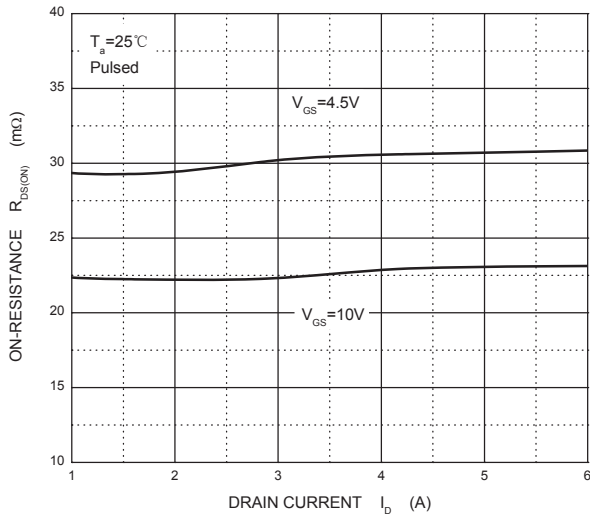

$R_{DS(ON)}$  —  $V_{GS}$

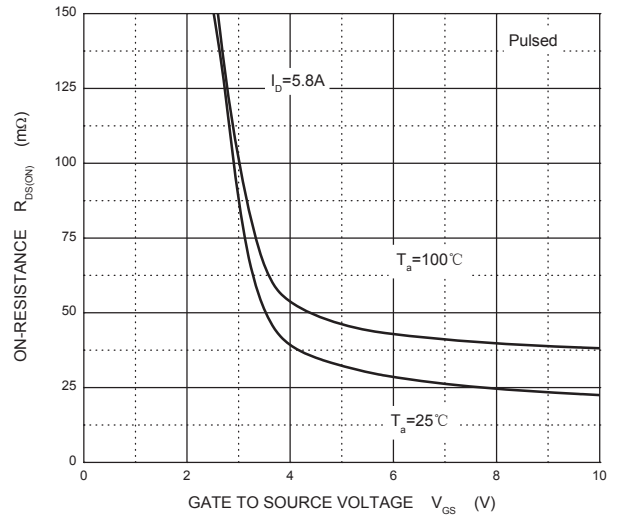

$I_S$  —  $V_{SD}$

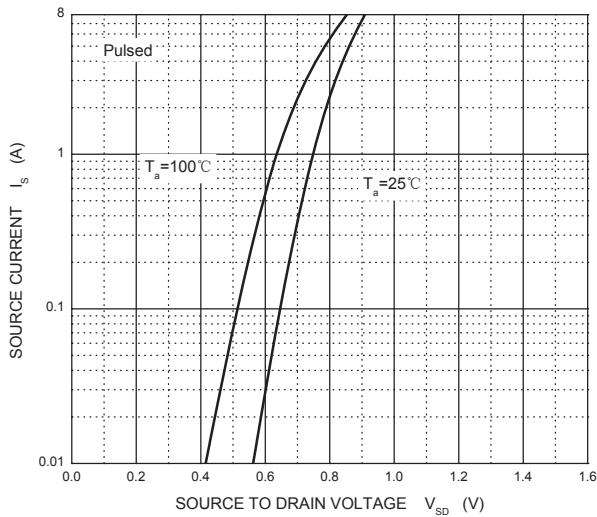

Threshold Voltage

