

SOT-23 Plastic-Encapsulate MOSFETS

Features

- VDS (V) = 20V
- ID = 4.2A(VGS=4.5V)
- RDS(ON) < 50mΩ (VGS =4.5V)
- RDS(ON) < 63mΩ (VGS =2.5V)
- RDS(ON) < 87mΩ (VGS =1.8V)
- N-Channel Enhancement Mode Field Effect Transistor

MECHANICAL DATA

- Case style:SOT-23molded plastic
- Mounting position:any

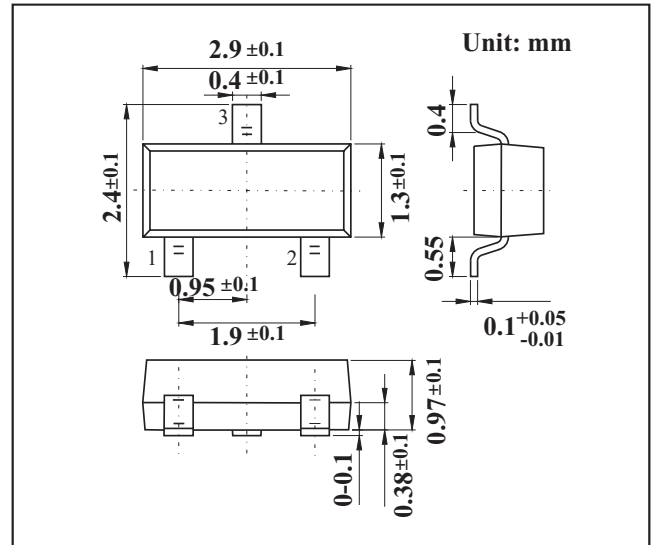

MAXIMUM RATINGS AND CHARACTERISTICS

@ 25°C Ambient Temperature (unless otherwise noted)

Parameter	Symbol	Rating	Unit
Drain-Source Voltage	V _{DS}	20	V
Gate-Source Voltage	V _{GS}	±8	V
Continuous Drain Current *1 T _A =25°C	I _D	4.2	A
Current *1 T _A =70°C		3.2	
Pulsed Drain Current *2	I _{DM}	15	
Power Dissipation *1 T _A =25°C	P _D	1.4	W
T _A =70°C		0.9	
Thermal Resistance.Junction-to-Ambient *1	R _{thJA}	125	°C/W
Thermal Resistance.Junction-to-Case	R _{thJC}	80	°C/W
Junction and Storage Temperature Range	T _J , T _{STG}	-55 to 150	°C

*1The value of R_{thJA} is measured with the device mounted on 1in² FR-4 board with 2oz.

Copper, in a still air environment with T_A =25°C



MOSFET ELECTRICAL CHARACTERISTICS Ta=25 °C unless otherwise specified

Parameter	Symbol	Testconditons	Min	Typ	Max	Unit
Drain-Source Breakdown Voltage	V _{DSS}	I _D =250μA, V _{GS} =0V	20			V
Zero Gate Voltage Drain Current	I _{DSS}	V _{DS} =16V, V _{GS} =0V			1	μA
		V _{DS} =16V, V _{GS} =0V, T _J =55°C			5	
Gate-Body leakage current	I _{GSS}	V _{DS} =0V, V _{GS} =±8V			±100	nA
Gate Threshold Voltage	V _{GS(th)}	V _{DS} =V _{GS} I _D =250μA	0.4	0.6	1	V
Static Drain-Source On-Resistance	R _{DS(ON)}	V _{GS} =4.5V, I _D =4.2A		41	50	mΩ
		V _{GS} =4.5V, I _D =4.2A T _J =125°C		58	70	
		V _{GS} =2.5V, I _D =3.7A		52	63	
		V _{GS} =1.8V, I _D =3.2A		67	87	
On state drain current	I _{D(ON)}	V _{GS} =4.5V, V _{DS} =5V	15			A
Forward Transconductance	g _{FS}	V _{DS} =5V, I _D =4.2A		11		S
Input Capacitance	C _{iss}			436		pF
Output Capacitance	C _{oss}	V _{GS} =0V, V _{DS} =-10V, f=1MHz		66		pF
Reverse Transfer Capacitance	C _{rss}			44		pF
Gate resistance	R _g	V _{GS} =0V, V _{DS} =0V, f=1MHz		3		Ω
Total Gate Charge	Q _g			6.2		nC
Gate Source Charge	Q _{gs}	V _{GS} =4.5V, V _{DS} =10V, I _D =4.2A		1.6		nC
Gate Drain Charge	Q _{gd}			0.5		nC
Turn-On DelayTime	t _{D(on)}			5.5		ns
Turn-On Rise Time	t _r			6.3		ns
Turn-Off DelayTime	t _{D(off)}	V _{GS} =4.5V, V _{DS} =10V, R _L =2.7Ω, R _{GEN} =6Ω		40		ns
Turn-Off FallTime	t _f			12.7		ns
Body Diode Reverse Recovery Time	t _{rr}	I _F =4A, di/dt=100A/μs		12.3		ns
Body Diode Reverse Recovery Charge	Q _{rr}	I _F =4A, di/dt=100A/μs		3.5		nC
Maximum Body-Diode Continuous Current	I _S				2	A
Diode Forward Voltage	V _{SD}	I _S =1A, V _{GS} =0V		0.76	1	V

RATINGS AND CHARACTERISTIC CURVES

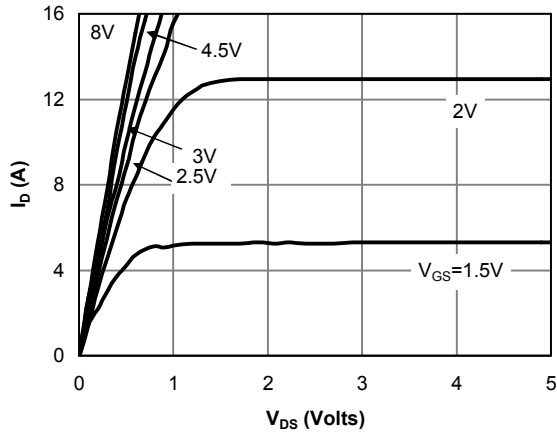

Fig 1: On-Region Characteristics

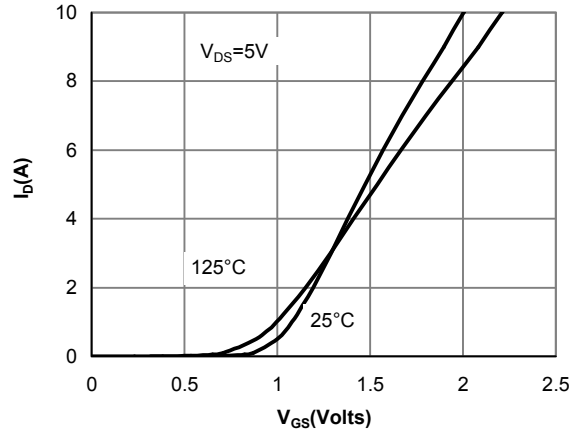

Figure 2: Transfer Characteristics

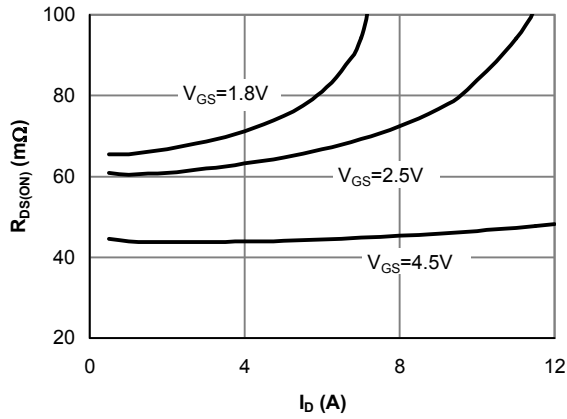

Figure 3: On-Resistance vs. Drain Current and Gate Voltage

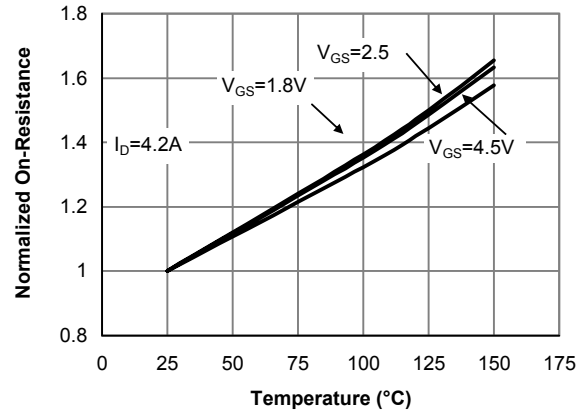

Figure 4: On-Resistance vs. Junction Temperature

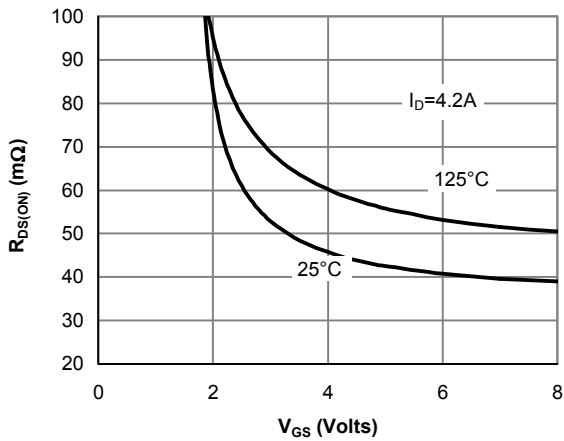

Figure 5: On-Resistance vs. Gate-Source Voltage

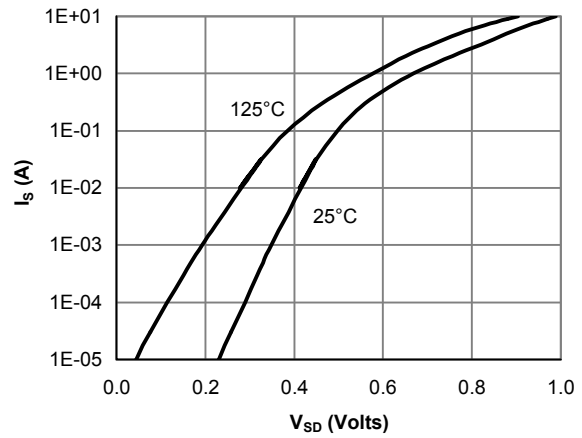

Figure 6: Body-Diode Characteristics

RATINGS AND CHARACTERISTIC CURVES

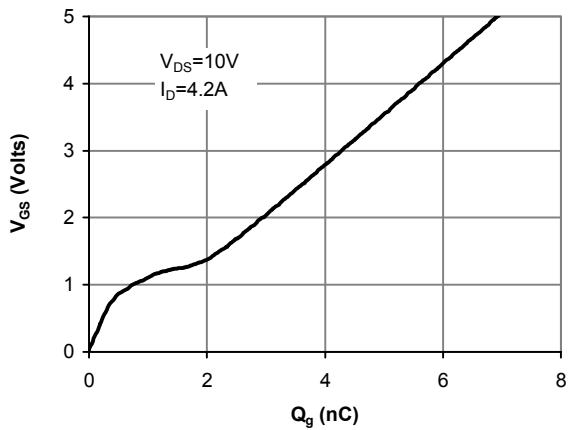

Figure 7: Gate-Charge Characteristics

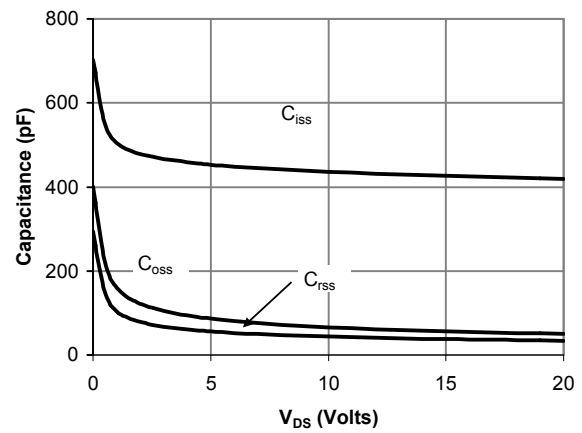

Figure 8: Capacitance Characteristics

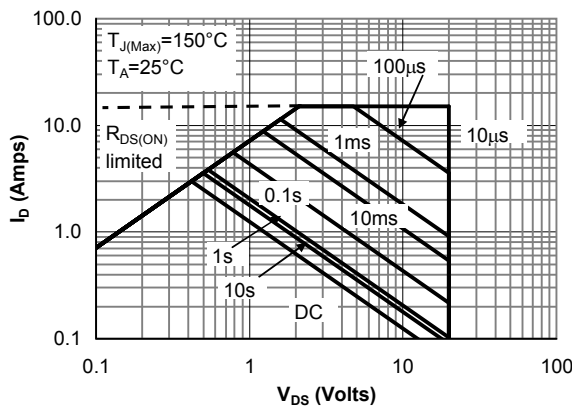

Figure 9: Maximum Forward Biased Safe Operating Area (Note E)

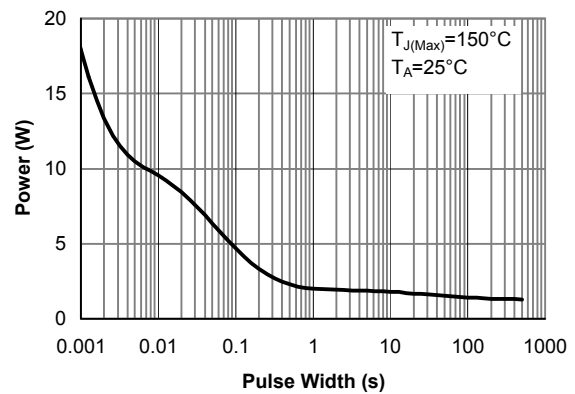

Figure 10: Single Pulse Power Rating Junction-to-Ambient (Note E)

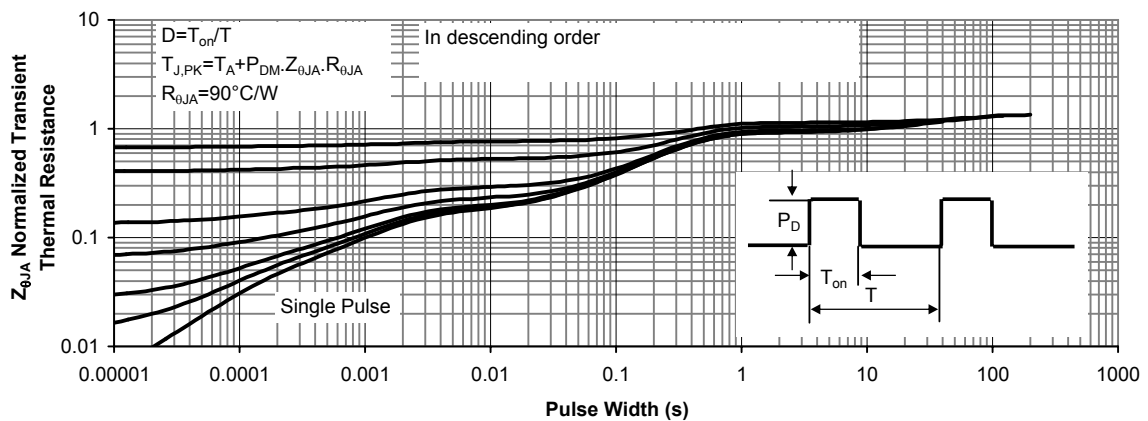

Figure 11: Normalized Maximum Transient Thermal Impedance