

TO-220-3L Plastic-Encapsulate MOSFETS

Features

- Low RDS(on)
- Lower Capacitances
- Lower Total Gate Charge
- Tighter VSD Specifications
- Avalanche Energy Specified
- 600V N-Channel MOSFET

MECHANICAL DATA

- Case style: TO-220-3L molded plastic
- Mounting position: any

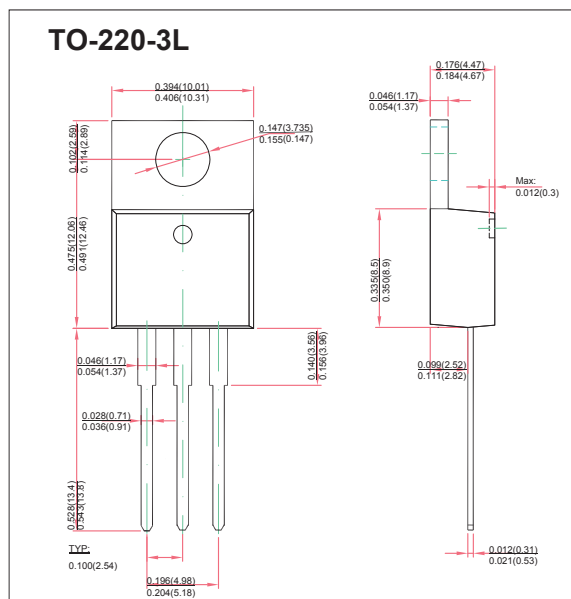

MAXIMUM RATINGS AND CHARACTERISTICS

@ 25°C Ambient Temperature (unless otherwise noted)

Parameter	Symbol	Value	Unit
Drain-Source Voltage	V_{DS}	600	V
Gate-Source Voltage	V_{GS}	± 30	
Continuous Drain Current	I_D	4.5	A
Single Pulsed Avalanche Energy (note1)	E_{AS}	250	mJ
Power Dissipation (note2, $T_a=25^\circ\text{C}$)	P_D	2	W
Maximum Power Dissipation (note3, $T_c=25^\circ\text{C}$)		120	
Thermal Resistance from Junction to Ambient	$R_{\theta JA}$	62.5	$^\circ\text{C}/\text{W}$
Junction Temperature	T_J	150	$^\circ\text{C}$
Storage Temperature	T_{stg}	-50 ~ +150	

**RATINGS AND CHARACTERISTIC CURVES****MOSFET ELECTRICAL CHARACTERISTICS** $T_A=25^\circ\text{C}$ unless otherwise specified

Parameter	Symbol	Test Condition	Min	Typ	Max	Units
Gate-Body Leakage Current (note 4)	I_{GSS}	$V_{DS}=0V, V_{GS}=\pm 30V$			± 100	nA
Drain-Source Breakdown Voltage	$V_{(BR)DSS}$	$V_{GS}=0V, I_D=250\mu A$	600			V
Gate-Threshold Voltage	$V_{GS(th)}$		2.0		4.0	
Zero Gate Voltage Drain Current	I_{DSS}	$V_{DS}=600V, V_{GS}=0V$			1	μA
Forward transconductance	g_{fs}	$V_{DS}=40V, I_D=2.25A$	2.9			S
Drain-Source On-State Resistance	$R_{DS(on)}$	$V_{GS}=10V, I_D=2.25A$			2.5	Ω
Input Capacitance	C_{iss}	$V_{DS}=25V, V_{GS}=0V, f=1MHz$			670	pF
Output Capacitance	C_{oss}				72	
Reverse Transfer Capacitance	C_{rss}				8.5	
Turn-On Delay Time (note 4)	$t_{d(on)}$	$V_{DD}=300V, I_D=4.5A, R_G=25\Omega$			30	ns
Rise Time (note 4)	t_r				90	
Turn-Off Delay Time (note 4)	$t_{d(off)}$				85	
Fall Time (note 4)	t_f				100	
Forward on Voltage (note 4)	V_{SD}	$V_{GS}=0V, I_S=4.5A$			1.4	V

Notes:

1. E_{AS} condition: $T_j=25^\circ\text{C}$, $V_{DD}=50V, R_G=25\Omega, L=16mH, I_{AS}=5A$
2. This test is performed with no heat sink at $T_a=25^\circ\text{C}$.
3. This test is performed with infinite heat sink at $T_c=25^\circ\text{C}$.
4. Pulse Test : Pulse Width $\leq 300\mu s$, Duty Cycle $\leq 2\%$.