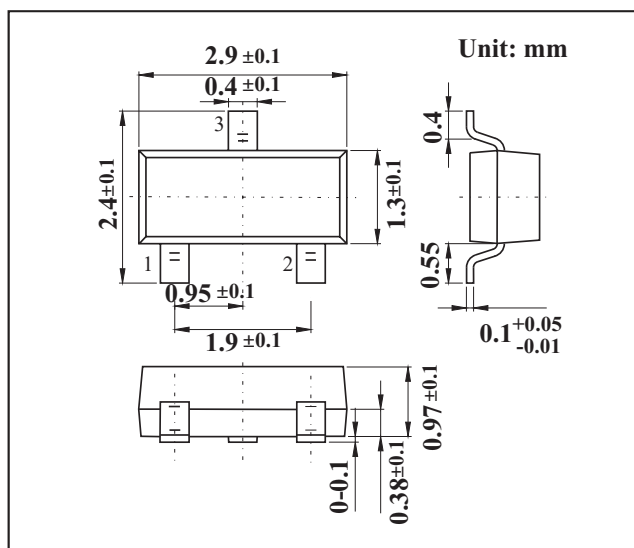

SOT-23 Plastic-Encapsulate MOSFETS
FEATURES

- VDS (V) = 100V
- ID =0.17A(VGS =10V)
- RDS(ON) 6(=10V)VGS
- RDS(ON)10(VGS =4.5V)
- ESD Protected 2KV HBM
- N-Channel MOSFET

MECHANICAL DATA

- Case style:SOT-23molded plastic
- Mounting position:any

MAXIMUM RATINGS AND CHARACTERISTICS

@ 25°C Ambient Temperature (unless otherwise noted)

Parameter	Symbol	Rating	Unit
Drain-Source Voltage	V _{DS}	100	V
Gate-Source Voltage	V _{GS}	±20	
Continuous Drain Current	I _D	0.17	A
Pulsed Drain Current	I _{DM}	0.68	
Power Dissipation	P _D	0.36	W
Derate Above 25°C		2.8	°C/mW
Thermal Resistance, Junction-to-Ambient	R _{θJA}	350	°C/W
Junction Temperature	T _J	150	°C
Storage Temperature Range	T _{stg}	- 5 5 to 1 5 0	

MOSFET ELECTRICAL CHARACTERISTICS Ta=25 °C unless otherwise specified

Parameter	Symbol	Test Conditions	Min	Typ	Max	Unit
Drain-Source Breakdown Voltage	V _{DSS}	I _D =250 μA, V _{GS} =0V	100			V
Zero Gate Voltage Drain Current	I _{DSS}	V _{DS} =100V, V _{GS} =0V			1	μA
		V _{DS} =100V, V _{GS} =0V, T _J =55 °C			60	
Gate-Body Leakage Current	I _{GSS}	V _{DS} =0V, V _{GS} =±20V			±10	μA
Gate Threshold Voltage	V _{GS(th)}	V _{DS} =V _{GS} , I _D =1mA	0.8		2.8	V
Static Drain-Source On-Resistance	R _{DS(on)}	V _{GS} =10V, I _D =0.17A			6	Ω
		V _{GS} =10V, I _D =0.17A T _J =125 °C			12	
		V _{GS} =4.5V, I _D =0.17A			10	
On State Drain Current	I _{D(ON)}	V _{GS} =10V, V _{DS} =5V	0.68			A
Forward Transconductance	g _{FS}	V _{DS} =10V, I _D =0.17A	0.08			S
Input Capacitance	C _{iss}	V _{GS} =0V, V _{DS} =25V, f=1MHz		73		pF
Output Capacitance	C _{oss}			7		
Reverse Transfer Capacitance	C _{rss}			3.4		
Gate Resistance	R _g	V _{GS} =15mV, f=1MHz		2.2		Ω
Total Gate Charge	Q _g	V _{GS} =10V, V _{DS} =30V, I _D =0.22A		1.8	2.5	nC
Gate Source Charge	Q _{gs}			0.2		
Gate Drain Charge	Q _{gd}			0.3		
Turn-On DelayTime	t _{d(on)}	V _{DD} = 3 0 V , I _D = 0 . 2 8 A , V _{GS} = 1 0 V , R _{GEN} = 6 Ω		1.7	3.4	ns
Turn-On Rise Time	t _r			9	18	
Turn-Off DelayTime	t _{d(off)}			17	31	
Turn-Off Fall Time	t _f			2.4	5	
Body Diode Reverse Recovery Time	t _{rr}			11		
Body Diode Reverse Recovery Charge	Q _{rr}	I _F = 0 . 1 7 A , d I / d t = 1 0 0 A / μs		3		nC
Maximum Body-Diode Continuous Current	I _S				0.17	A
Diode Forward Voltage	V _{SD}	I _S =0.34A,V _{GS} =0V			1.3	V

RATINGS AND CHARACTERISTIC CURVES

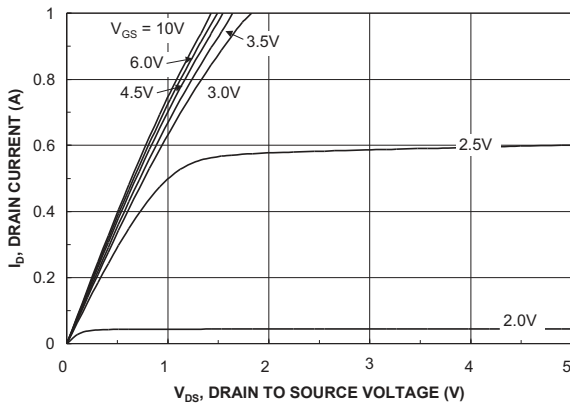

Figure 1. On-Region Characteristics.

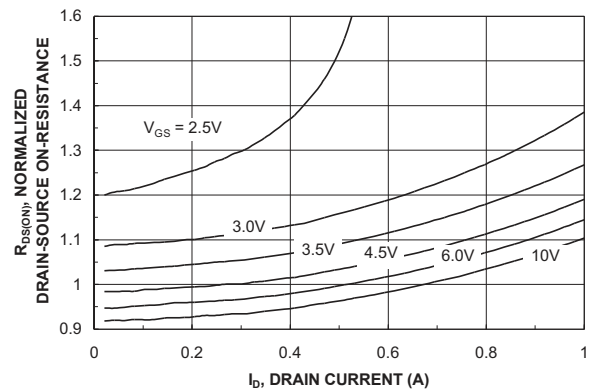

Figure 2. On-Resistance Variation with Drain Current and Gate Voltage.

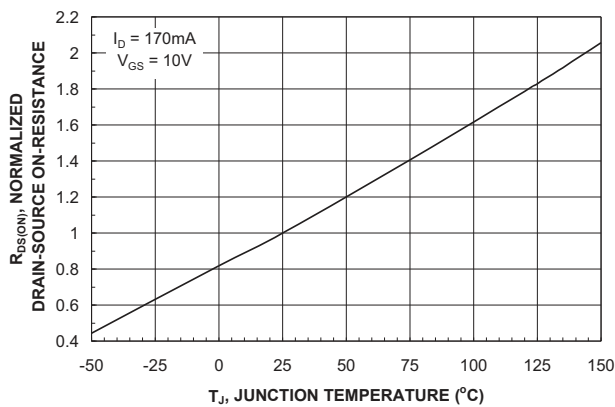

Figure 3. On-Resistance Variation with Temperature.

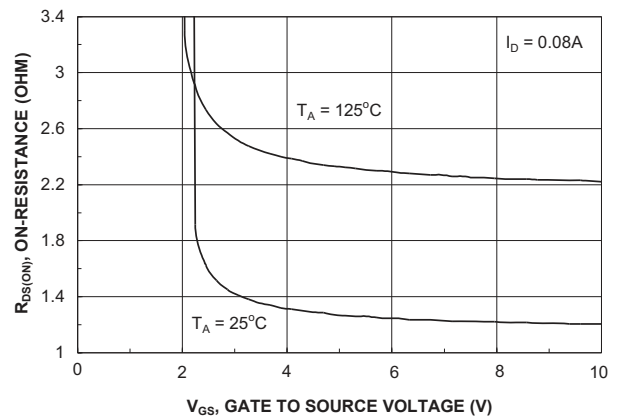

Figure 4. On-Resistance Variation with Gate-to-Source Voltage.

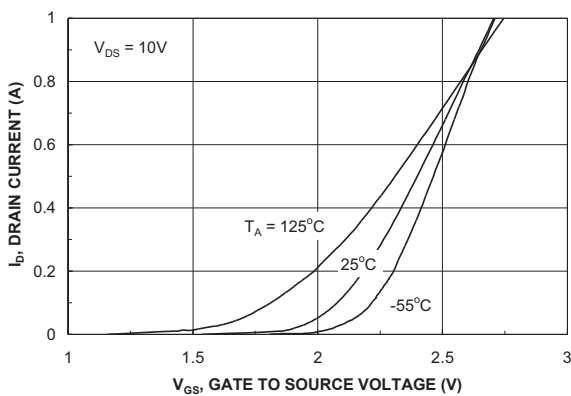

Figure 5. Transfer Characteristics.

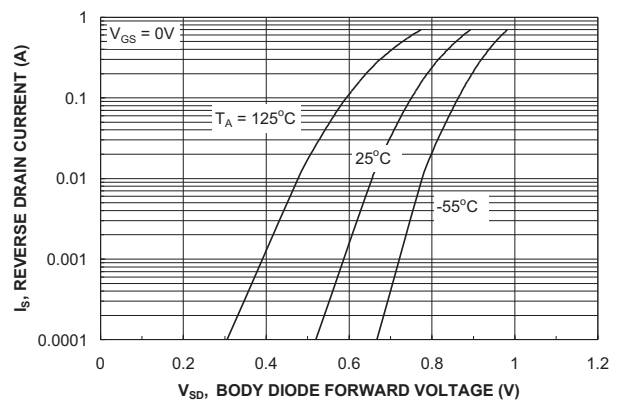

Figure 6. Body Diode Forward Voltage Variation with Source Current and Temperature.

RATINGS AND CHARACTERISTIC CURVES

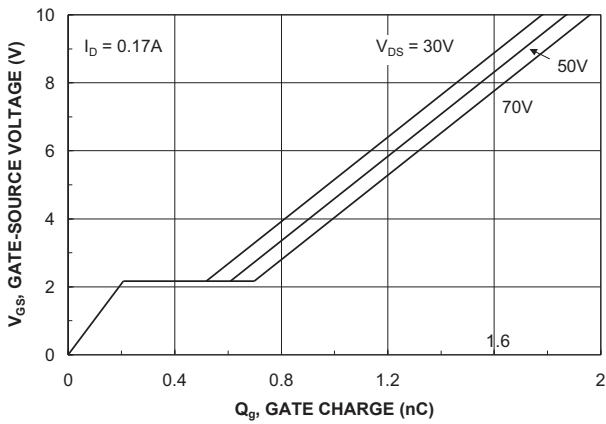

Figure 7. Gate Charge Characteristics.

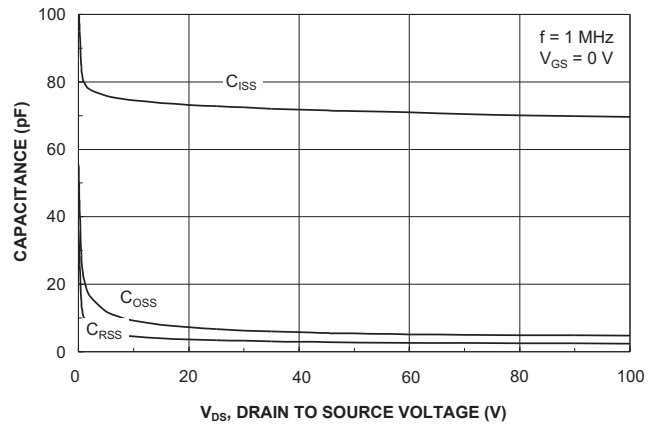

Figure 8. Capacitance Characteristics.

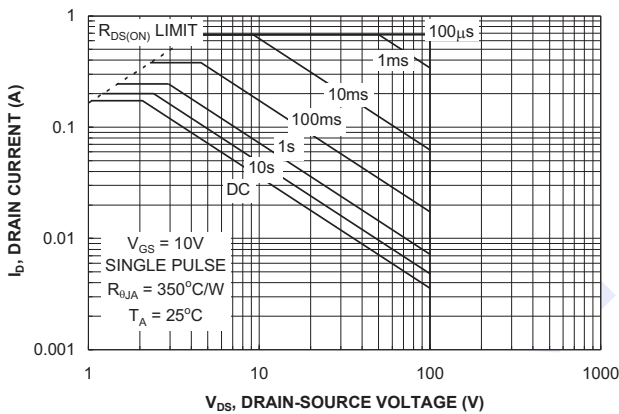

Figure 9. Maximum Safe Operating Area.

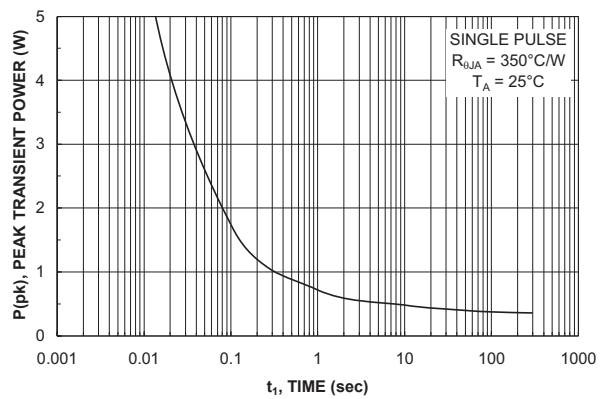

Figure 10. Single Pulse Maximum Power Dissipation.

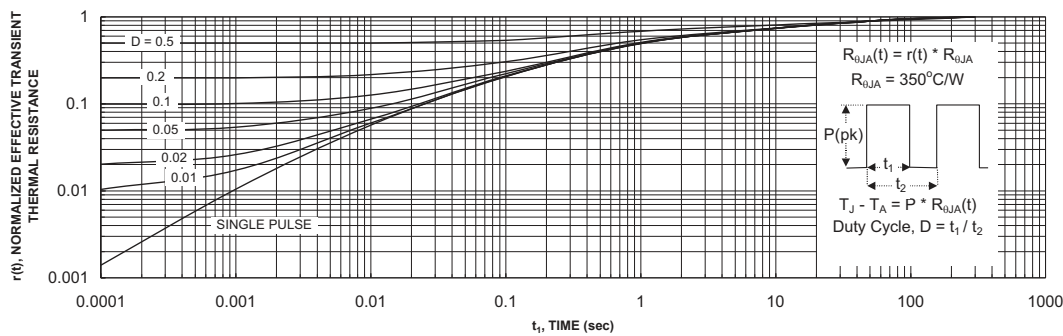

Figure 11. Transient Thermal Response Curve.

Thermal characterization performed using the conditions described in Note 1a. Transient thermal response will change depending on the circuit board design.