

SOT-23 Plastic-Encapsulate MOSFETS

FEATURE

- N-Channel Enhancement-Mode MOSFETS

MECHANICAL DATA

- Case style:SOT-23molded plastic
- Mounting position:any

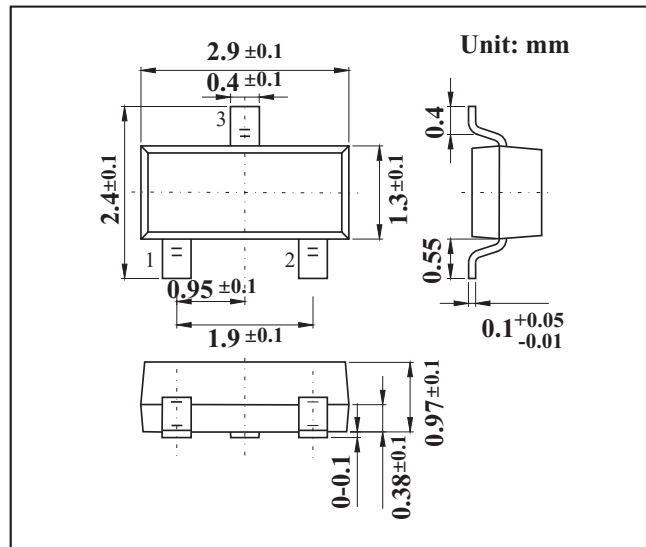

MAXIMUM RATINGS AND CHARACTERISTICS

@ 25°C Ambient Temperature (unless otherwise noted)

Characteristic	Symbol	Max	Unit
Drain-Source Voltage	BV_{DSS}	55	V
Gate- Source Voltage	V_{GS}	+12 -	V
Drain Current (continuous)	I_D	2.1	A
Drain Current (pulsed)	I_{DM}	10	A
Total Device Dissipation $T_A=25^\circ\text{C}$	P_D	1250	mW
Junction	T_J	150	$^\circ\text{C}$
Storage Temperature	T_{stg}	-55to+150	$^\circ\text{C}$



RATINGS AND CHARACTERISTIC CURVES

MOSFET ELECTRICAL CHARACTERISTICS $T_a=25\text{ }^\circ\text{C}$ unless otherwise specified

Characteristic	Symbol	Min	Typ	Max	Unit
Drain-Source Breakdown Voltage ($I_D = 10\text{mA}, V_{GS}=0\text{V}$)	BV_{DSS}	55	—	—	V
Gate Threshold Voltage ($I_D = 250\text{uA}, V_{GS} = V_{DS}$)	$V_{GS(th)}$	0.6	—	2	V
Diode Forward Voltage Drop ($I_S=1\text{A}, V_{GS}=0\text{V}$)	V_{SD}	—	—	1	V
Zero Gate Voltage Drain Current $V_{GS}=0\text{V}, V_{DS}= 44\text{V},$ ($V_{GS}=0\text{V}, V_{DS}= 44\text{V}, T_A=55\text{ }^\circ\text{C}$)	I_{DSS}	—	—	1 5	μA
Gate Body Leakage ($V_{GS} = \pm 12\text{V}, V_{DS}=0\text{V}$)	I_{GSS}	—	—	± 100	nA
Static Drain-Source On-State Resistance($I_D= 2.1\text{A}, V_{GS}= 4.5\text{V}$)	$R_{DS(ON)}$	—	125	160	$\text{m}\Omega$
Static Drain-Source On-State Resistance($I_D= 1.5\text{A}, V_{GS}= 2.5\text{V}$)	$R_{DS(ON)}$	—	160	200	$\text{m}\Omega$
Input Capacitance ($V_{GS}=0\text{V}, V_{DS}= 25\text{V}, f=1\text{MHz}$)	C_{ISS}	—	214	—	pF
Output Capacitance ($V_{GS}=0\text{V}, V_{DS}= 25\text{V}, f=1\text{MHz}$)	C_{OSS}	—	31	—	pF
Turn-ON Time ($V_{DS}= 30\text{V}, V_{GS}=10\text{V}, R_{GEN}=3\Omega$)	$t_{(on)}$	—	2	—	n s
Turn-OFF Time ($V_{DS}= 30\text{V}, V_{GS}=10\text{V}, R_{GEN}=3\Omega$)	$t_{(off)}$	—	16	—	n s

Pulse Width $\leq 300\mu\text{s}$; Duty Cycle $\leq 2.0\%$

RATINGS AND CHARACTERISTIC CURVES

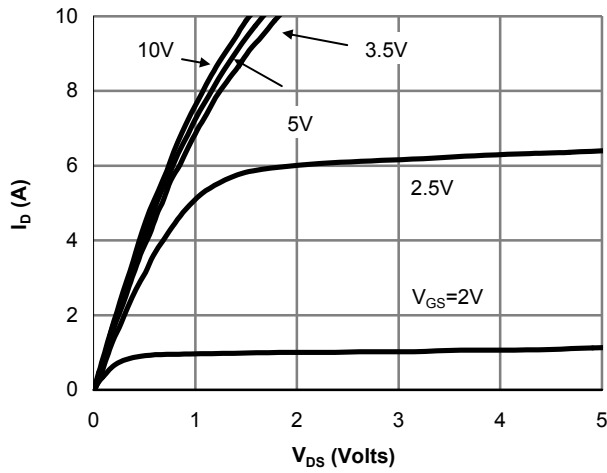

Fig 1: On-Region characteristics

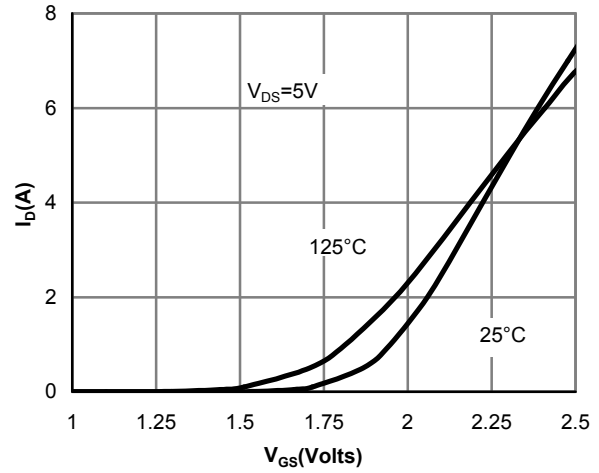

Figure 2: Transfer Characteristics

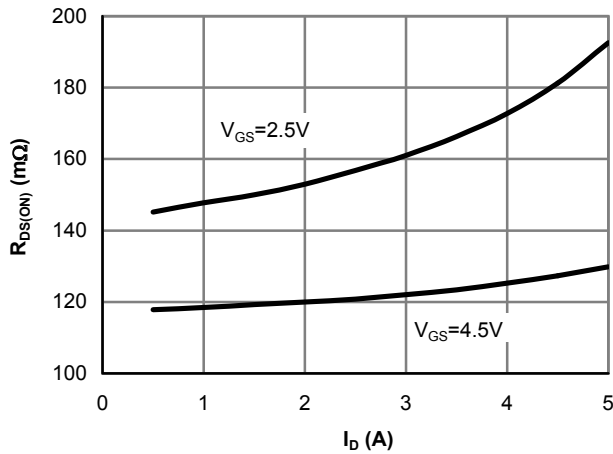

Figure 3: On-Resistance vs. Drain Current and Gate Voltage

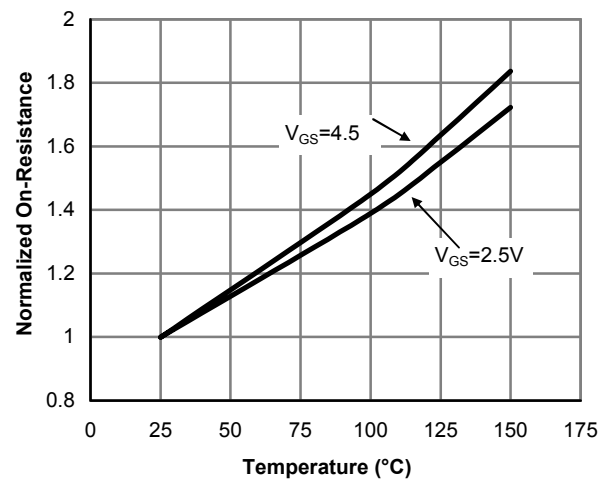

Figure 4: On-Resistance vs. Junction Temperature

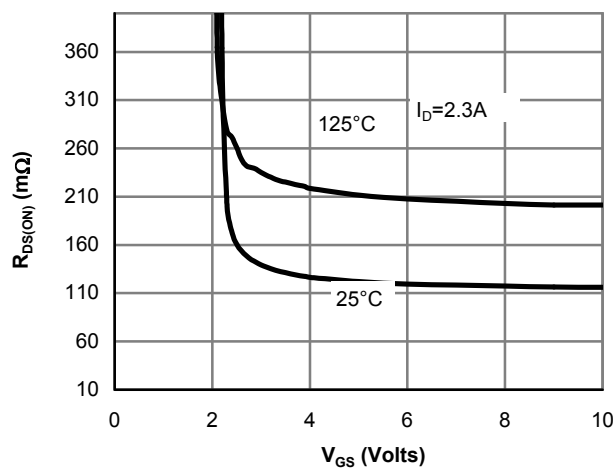

Figure 5: On-Resistance vs. Gate-Source Voltage

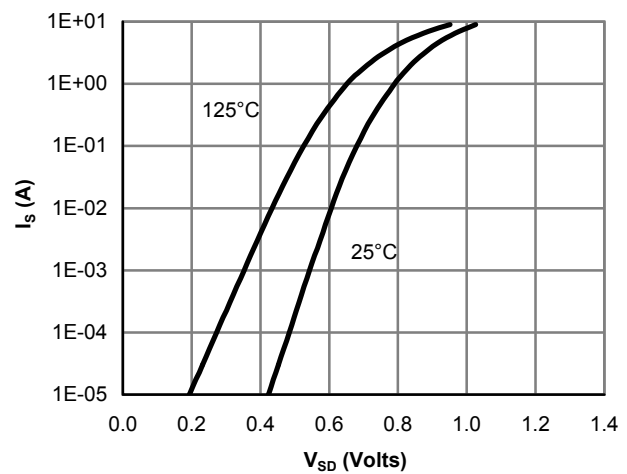

Figure 6: Body-Diode Characteristics

RATINGS AND CHARACTERISTIC CURVES

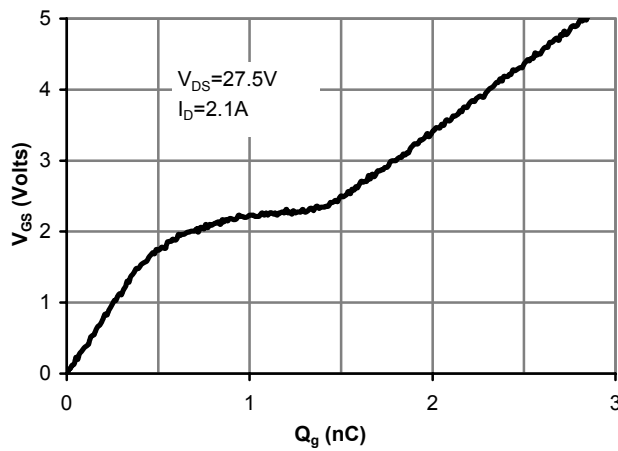

Figure 7: Gate-Charge Characteristics

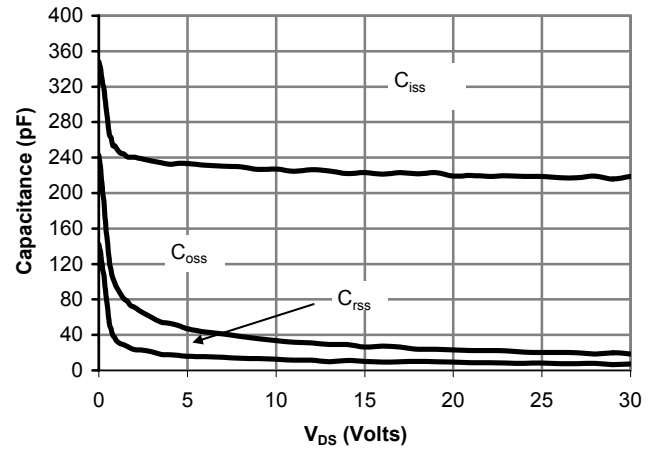

Figure 8: Capacitance Characteristics

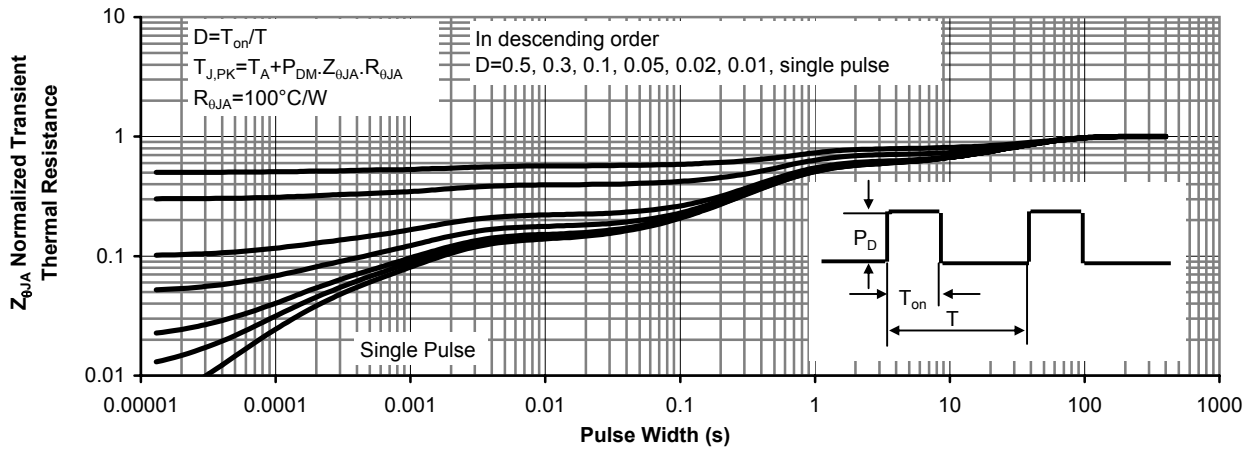

Figure 9: Normalized Maximum Transient Thermal Impedance