

SOT-23 Plastic-Encapsulate MOSFETS

FEATURE

- Low on-resistance
- Fast switching speed
- Low voltage drive makes this device ideal for
- Portable equipment
- Easily designed drive circuits
- Easy to parallel
- N-channel MOSFET

MECHANICAL DATA

- Case style:SOT-23molded plastic
- Mounting position:any

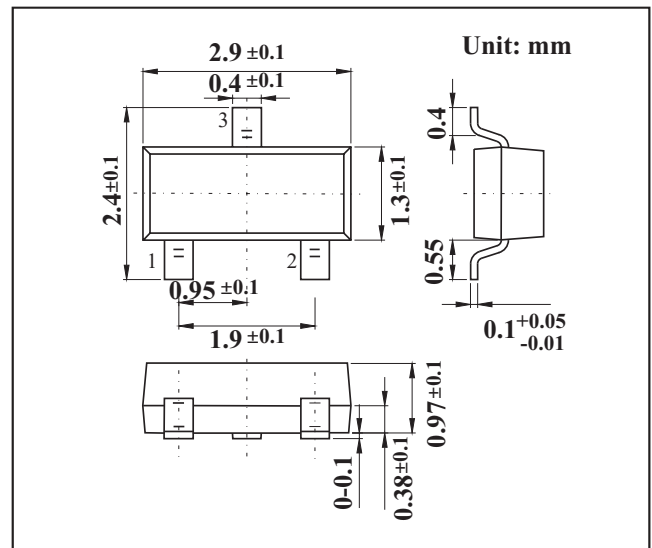

MAXIMUM RATINGS AND CHARACTERISTICS

@ 25°C Ambient Temperature (unless otherwise noted)

Parameter		Symbol	Limit	Unit
Drain-source Voltage		V_{DS}	60	V
Gate-source Voltage		V_{GS}	±20	V
Drain Current	$T_A=25^\circ\text{C}$	I_D	3	A
	$T_A=70^\circ\text{C}$		2.4	
Pulsed Drain Current ^A		I_{DM}	12	A
Total Power Dissipation @ $T_C=25^\circ\text{C}$		P_D	1.2	W
Thermal Resistance Junction-to-Ambient ^B		$R_{\theta JA}$	105	°C/W
Junction and Storage Temperature Range		T_J, T_{STG}	-55~+150	°C



Parameter	Symbol	Conditions	Min	Typ	Max	Units
Static Parameter						
Drain-Source Breakdown Voltage	BV_{DSS}	$V_{GS}=0V, I_D=250\mu A$	60			V
Zero Gate Voltage Drain Current	I_{DSS}	$V_{DS}=60V, V_{GS}=0V$			1	μA
Gate-Body Leakage Current	I_{GSS1}	$V_{GS}=\pm 20V, V_{DS}=0V$			± 100	nA
	I_{GSS2}	$V_{GS}=\pm 10V, V_{DS}=0V$			± 50	nA
Gate Threshold Voltage	$V_{GS(th)}$	$V_{DS}=V_{GS}, I_D=250\mu A$	1.0	1.7	2.0	V
Static Drain-Source On-Resistance	$R_{DS(on)}$	$V_{GS}=10V, I_D=3A$		58	100	m Ω
		$V_{GS}=4.5V, I_D=1.5A$		70	110	
Diode Forward Voltage	V_{SD}	$I_S=3.0A, V_{GS}=0V$		0.8	1.2	V
Maximum Body-Diode Continuous Current	I_S				3.0	A
Dynamic Parameters						
Input Capacitance	C_{iss}	$V_{DS}=30V, V_{GS}=0V, f=1MHz$		330		pF
Output Capacitance	C_{oss}			90		
Reverse Transfer Capacitance	C_{rss}			17		
Switching Parameters						
Total Gate Charge	Q_g	$V_{GS}=10V, V_{DS}=30V, I_D=3.0A$		5.1		nC
Gate-Source Charge	Q_{gs}			1.3		
Gate-Drain Charge	Q_{gd}			1.7		
Turn-on Delay Time	$t_{D(on)}$	$V_{GS}=10V, V_{DD}=30V, I_D=1.5A, R_L=1\Omega, R_{GEN}=3\Omega$		13		ns
Turn-on Rise Time	t_r			51		
Turn-off Delay Time	$t_{D(off)}$			19		
Turn-off fall Time	t_f			12		

A. Pulse Test: Pulse Width $\leq 300\mu s$, Duty cycle $\leq 2\%$

B. Device mounted on FR-4 PCB, 1 inch x 0.85 inch x 0.062 inch

RATINGS AND CHARACTERISTIC CURVES

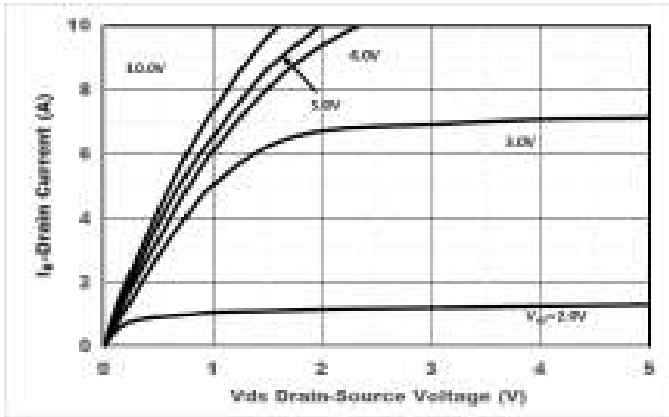

Figure1. Output Characteristics

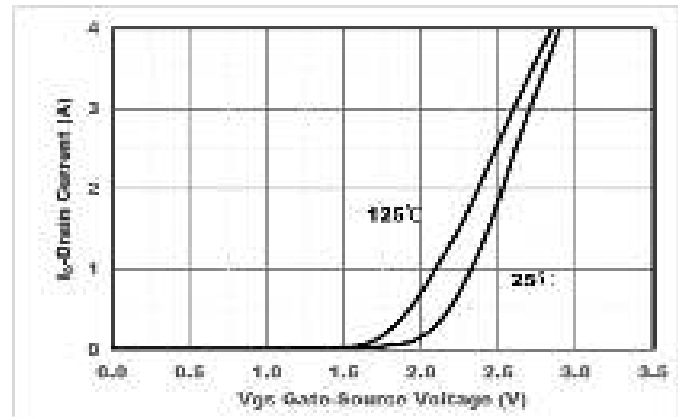

Figure2. Transfer Characteristics

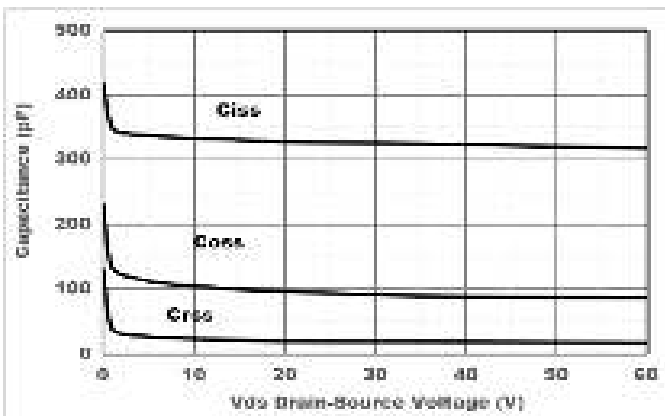

Figure3. Capacitance Characteristics

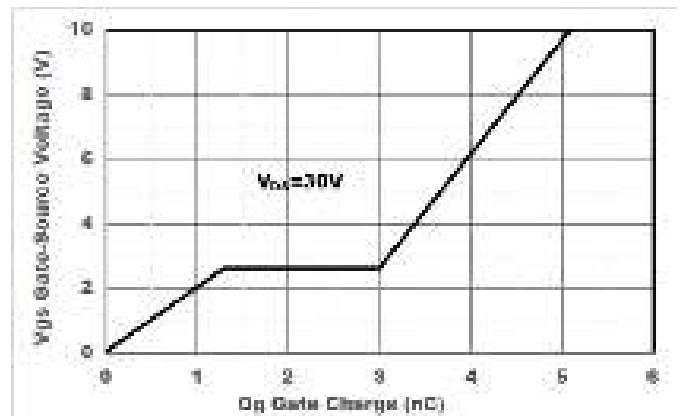

Figure4. Gate Charge

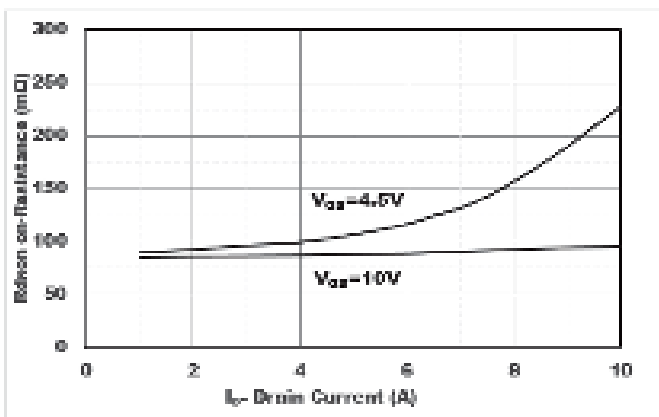

Figure5. Drain-Source on Resistance

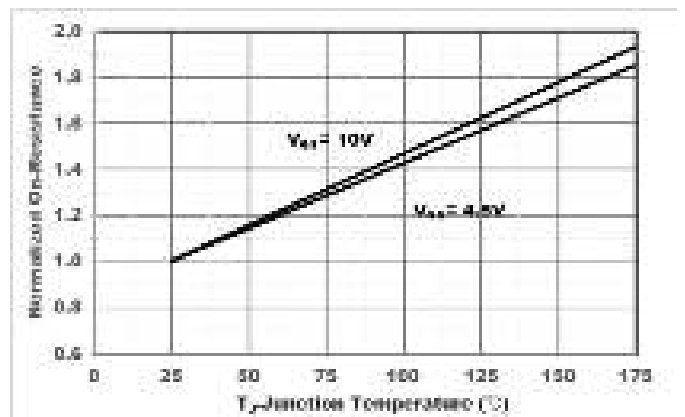

Figure6. Drain-Source on Resistance

RATINGS AND CHARACTERISTIC CURVES

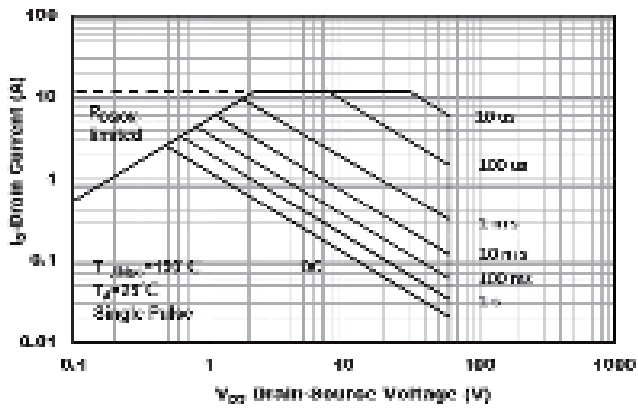

Figure7. Safe Operation Area

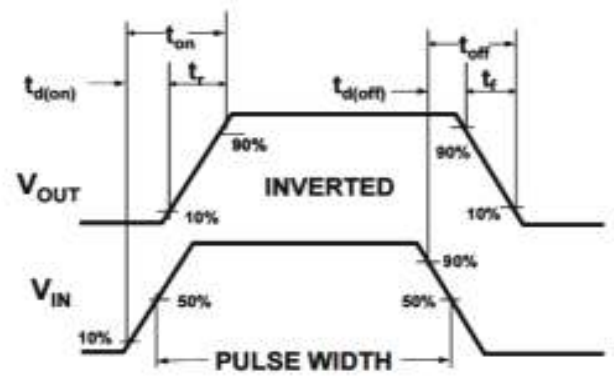

Figure8. Switching wave